



信息科学与技术学院

School of Information Science and Technology

# CS 110

# Computer Architecture

# Pipeline II

Instructors: Siting Liu & Yuan Xiao

Course website: <https://faculty.sist.shanghaitech.edu.cn/liust/courses/CS110.html>

School of Information Science and Technology (SIST)

ShanghaiTech University

2025/4/16

# Administratives

- Lab 7 released: project 1.1 check.
- HW 4 on-going, ddl April 21st! Start early!
  - The template is updated, please use the most up-to-date starter file!
- Project 1.2 on-going, DDL April 27th.
- Mid-term I Apr. 23rd 8:00am-10:00am
  - Location: Teaching center 301 (Siting's class);  
SIST1D107/108 (Yuan's class); Check on your egate;
  - Prepare your cheat sheet in advance!
  - Materials until Apr. 21st lecture.
- Discussion (SPST 4-122 18:00 - 19:40) schedule
  - Apr. 17th on mid-term I review by Chaofan Li;
  - Apr. 24th on datapath by Yuxuan Li.

# Outline

- Starting this lecture, we will improve the performance of our CPU
- Performance evaluation
- Pipeline
- Hazards
  - Structural hazards
  - Data hazards
  - **Control hazards**

# Detailed considerations

```

add t0,t1,t2
sw t4,0(t3)
lw t5,0(t6)
addi t6,x0,1
beq t0,t1,label
  
```

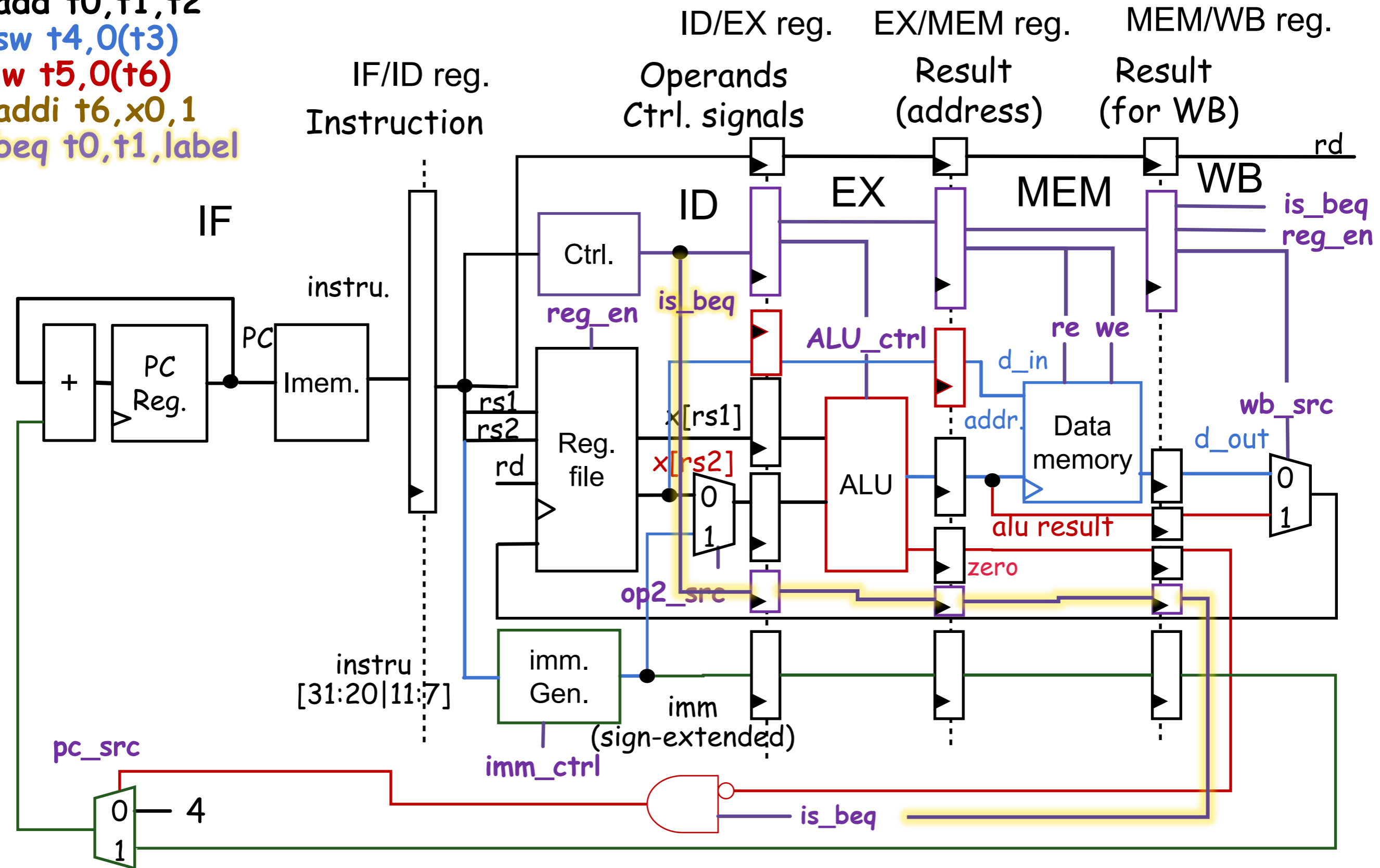

0x0:add t0,t1,t2  
 0x4:sw t4,0(t3)  
 0x8:lw t5,0(t6)  
 0xc:addi t6,x0,1  
 0x10:beq t0,t1,label  
 0x14:beq\_next1  
 0x18:beq\_next2  
 0x1c:beq\_next3  
 0x20:beq\_next4  
 0x24:beq\_next5

# Detailed considerations

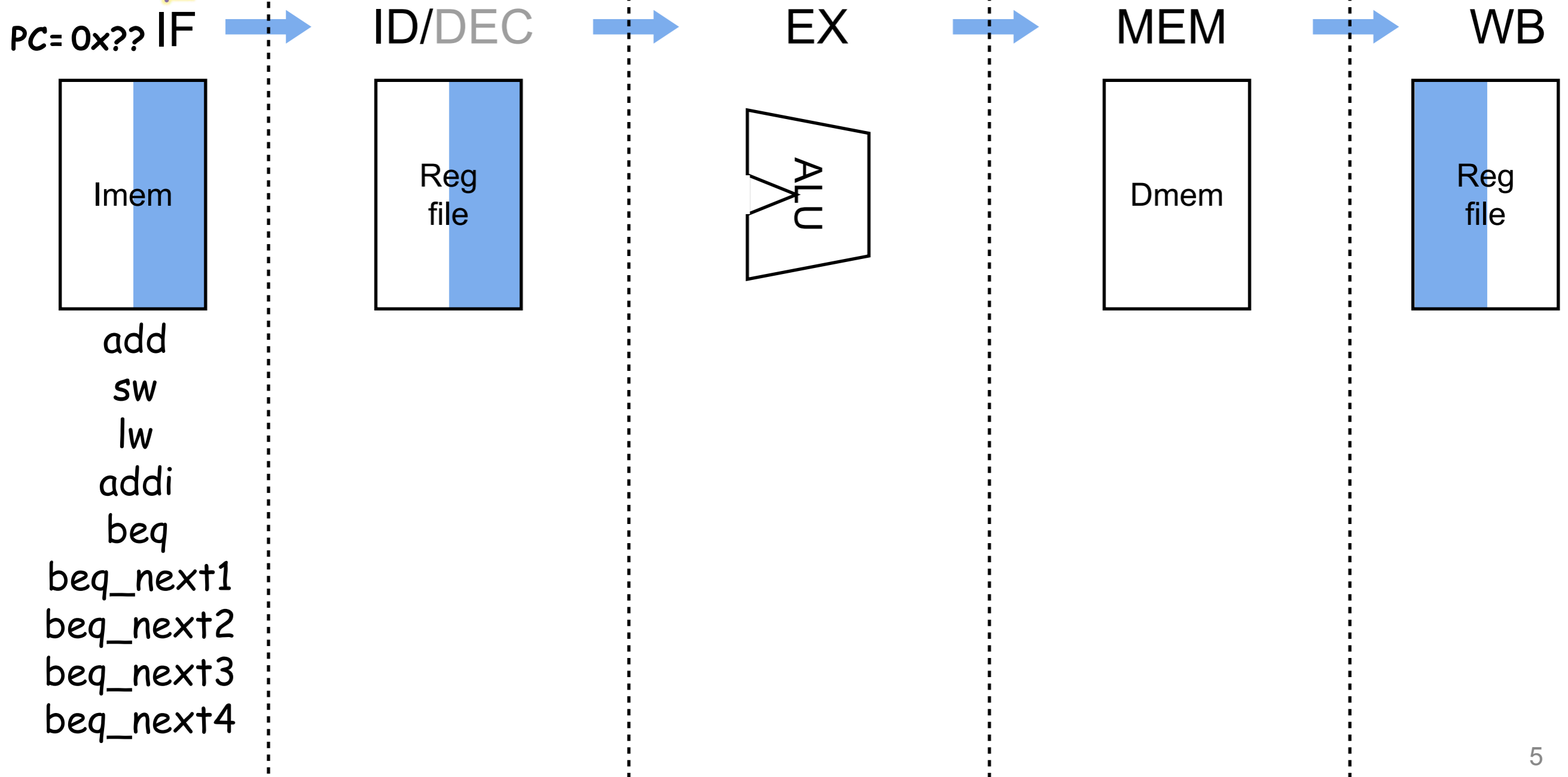

# Control hazards--solution 1

We can wait ...

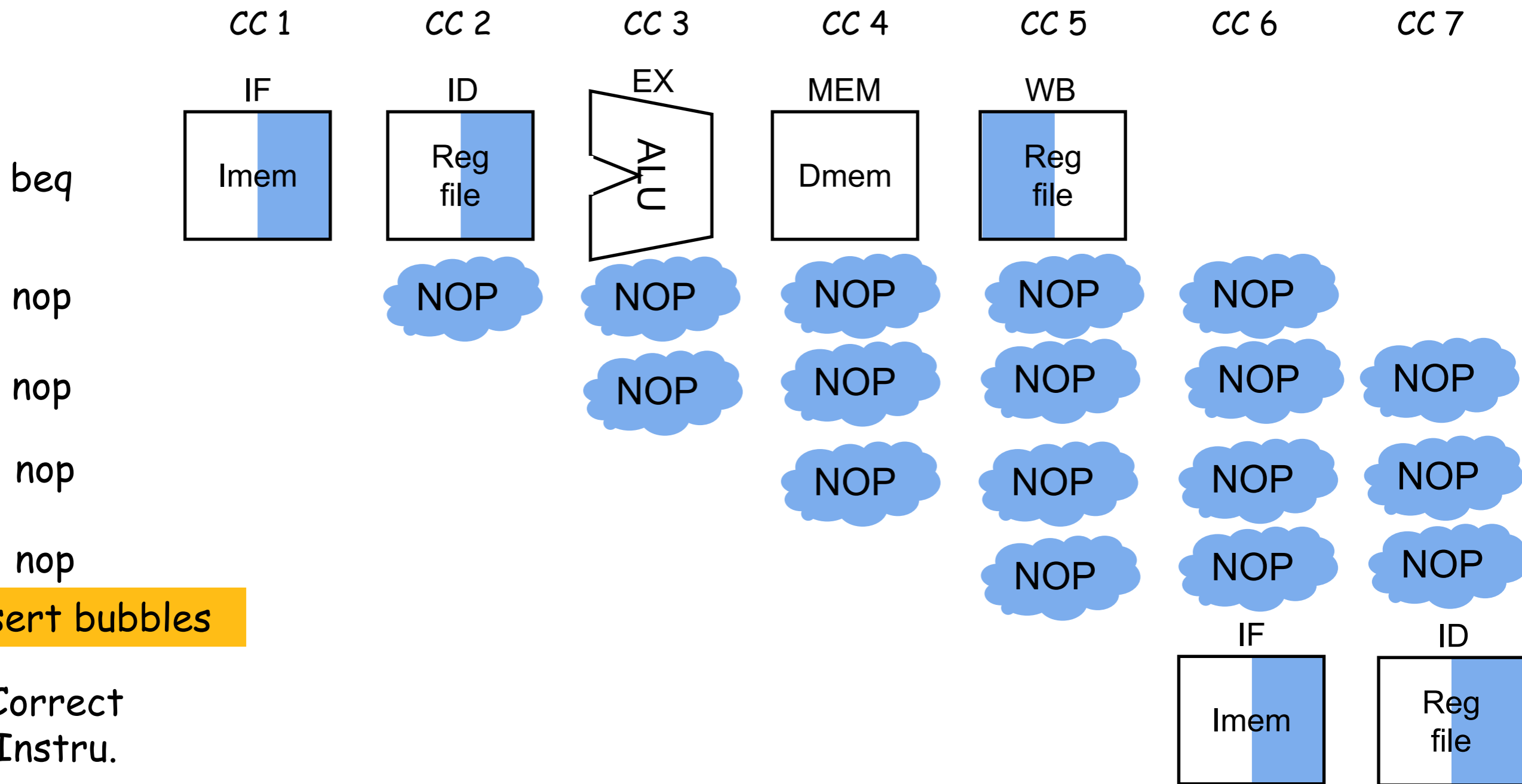

Insert bubbles

Correct Instru.

# Control hazards -- solution 2

- Assume branch not taken (static)
- Extra control logics to deal with the cases that the branches are taken
  - Flush the pipeline and restore the states

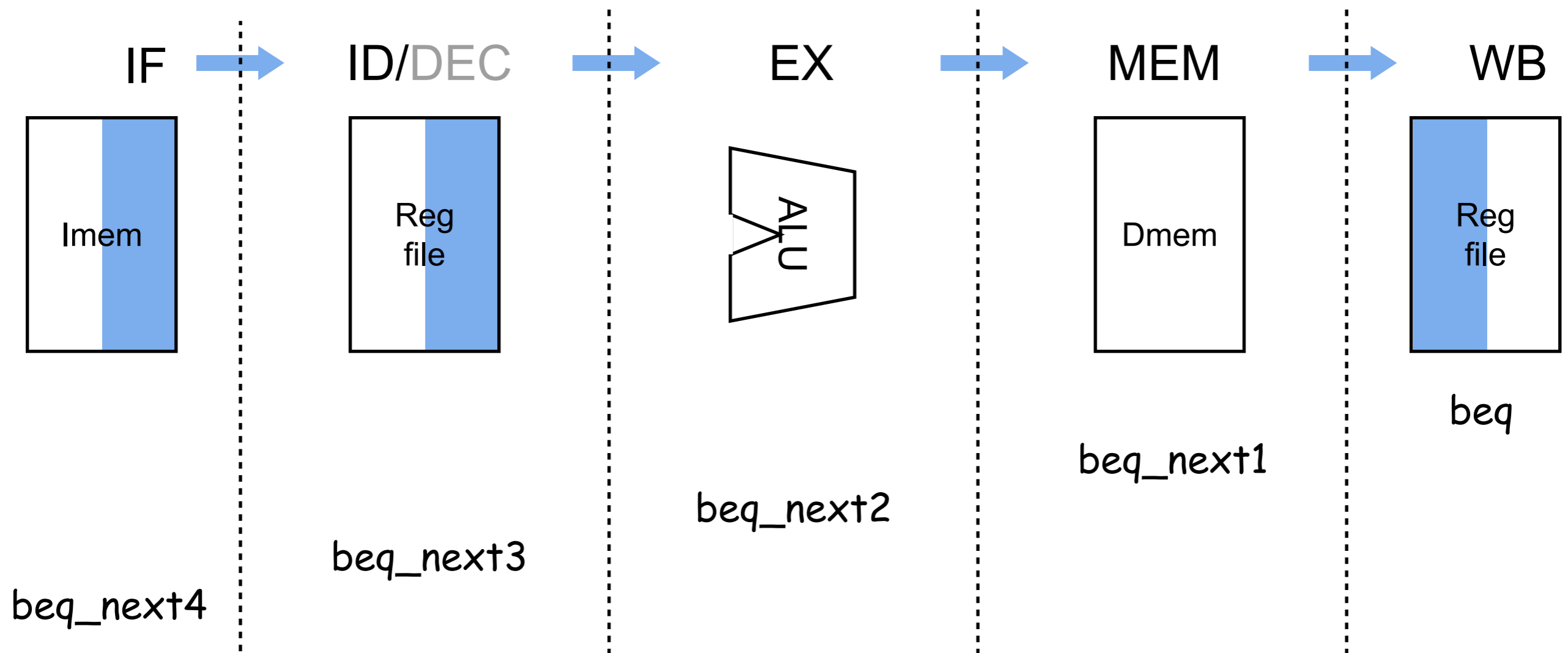

Speculation

# Control hazards -- solution 2

- Assume branch not taken (static)
- Not optimal in some cases

```
int A[20];  
int sum = 0;  
for (int i=0; i < 20; i++)  
    sum += A[i];
```

```
# Assume x8 holds pointer to A
```

```
# Assign x10=sum
```

```
add x10, x0, x0 # sum=0
```

```
add x11, x8, x0 # ptr = A
```

```
addi x12, x11, 80 # end = A + 80
```

```
Loop:
```

```
lw x13, 0(x11) # x13 = *ptr
```

```
add x10, x10, x13 # sum += x13
```

```
addi x11, x11, 4 # ptr++
```

```
blt x11, x12, Loop # ptr < end
```

Wrong speculations except  
the last branch

# Control hazards -- solution 2

- Alternatively, **dynamic** branch prediction (when the program is running)

```

int A[20];
int sum = 0;
for (int i=0; i < 20; i++)
    sum += A[i];

# Assume x8 holds pointer to A
# Assign x10=sum
add x10, x0, x0 # sum=0
add x11, x8, x0 # ptr = A
addi x12, x11, 80 # end = A + 80
Loop:
    lw x13, 0(x11) # x13 = *ptr
    add x10, x10, x13 # sum += x13
    addi x11, x11, 4 # ptr++
    blt x11, x12, Loop # ptr < end
  
```

- Record the position of branch
- Record if the branch is taken for this branch
- Predict if the branch will be taken based on the current record
- Can be modeled as an FSM
- Use one or more bits to represent “(strong) taken” or “(strong not taken)”

# Real stuff

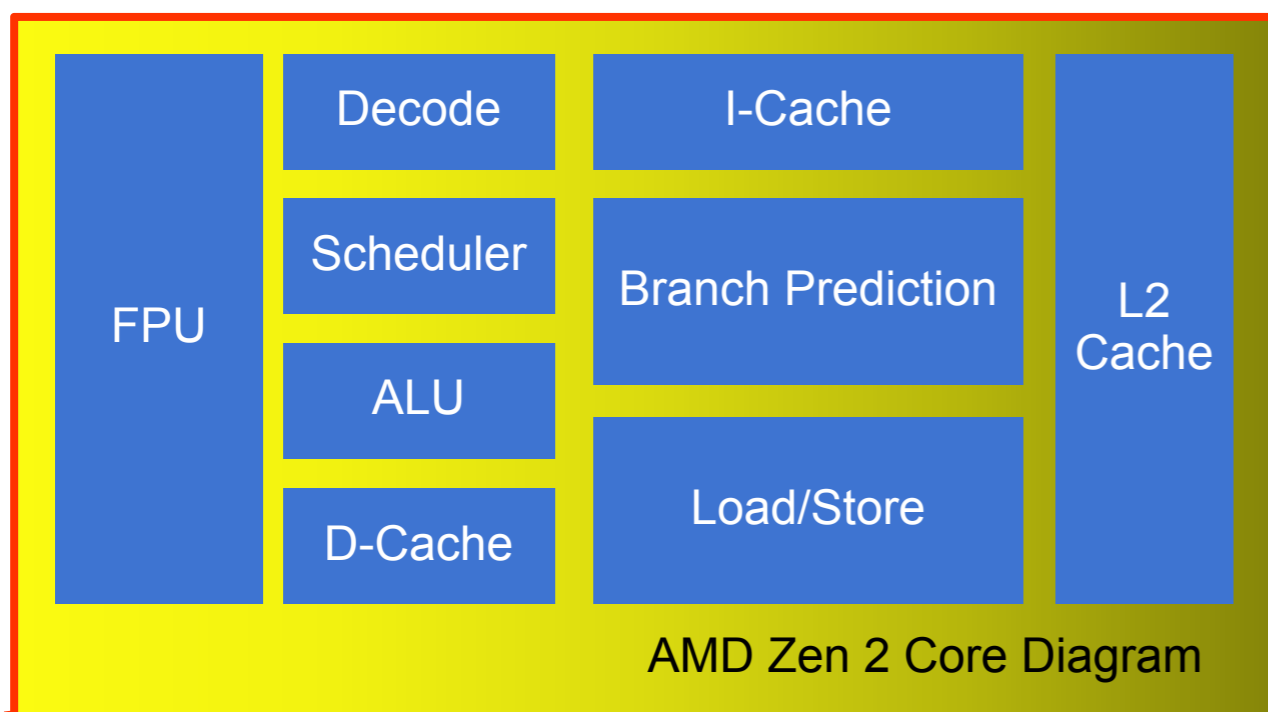

Unit	Zen	Zen 2
Floating Point	128b	256b
L0 Branch Target Buffer	8 entries	16 entries
L1 Branch Target Buffer	256 entries	512 entries
L2 Branch Target Buffer	4K entries	7K entries
Op Cache	2K ops	4K ops
Integer Physical Register File	168 entries	180 entries
Integer Scheduler	84 entries	92 entries
AGEN	2	3
ROB	192 entries	224 entries
L2DTLB	1.5K	2K
L3 Cache Size	8MB	16MB

7.83 mm<sup>2</sup> per core

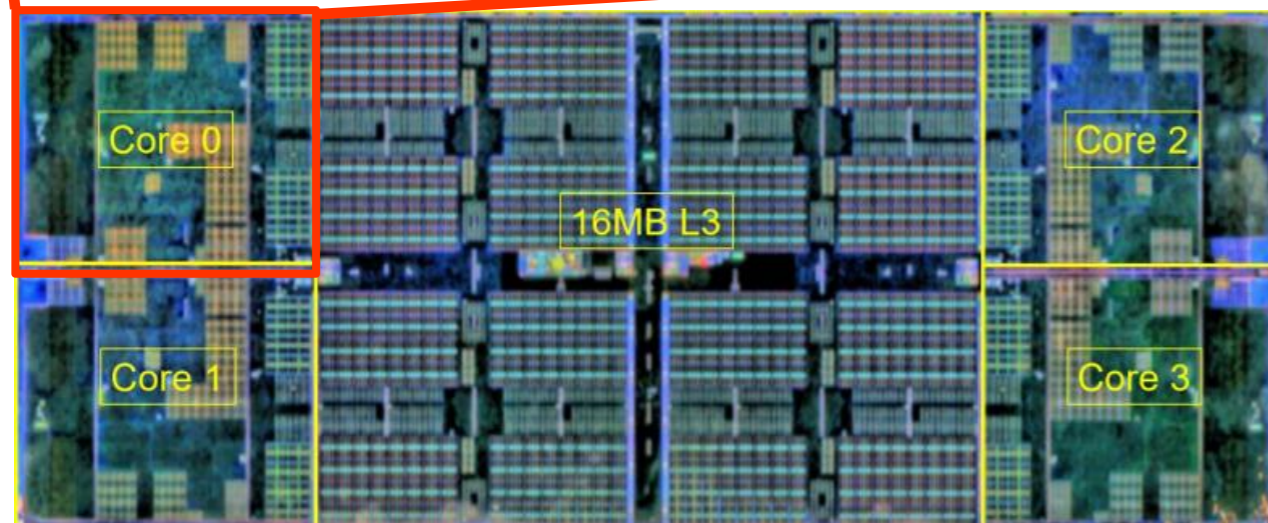

[1] T. Singh et al., "2.1 Zen 2: The AMD 7nm Energy-Efficient High-Performance x86-64 Microprocessor Core," IEEE International Solid-State Circuits Conference - (ISSCC), 2020, pp. 42-44.

# Control hazards -- solution 3

- Use idea similar to forwarding to reduce the delay of branches

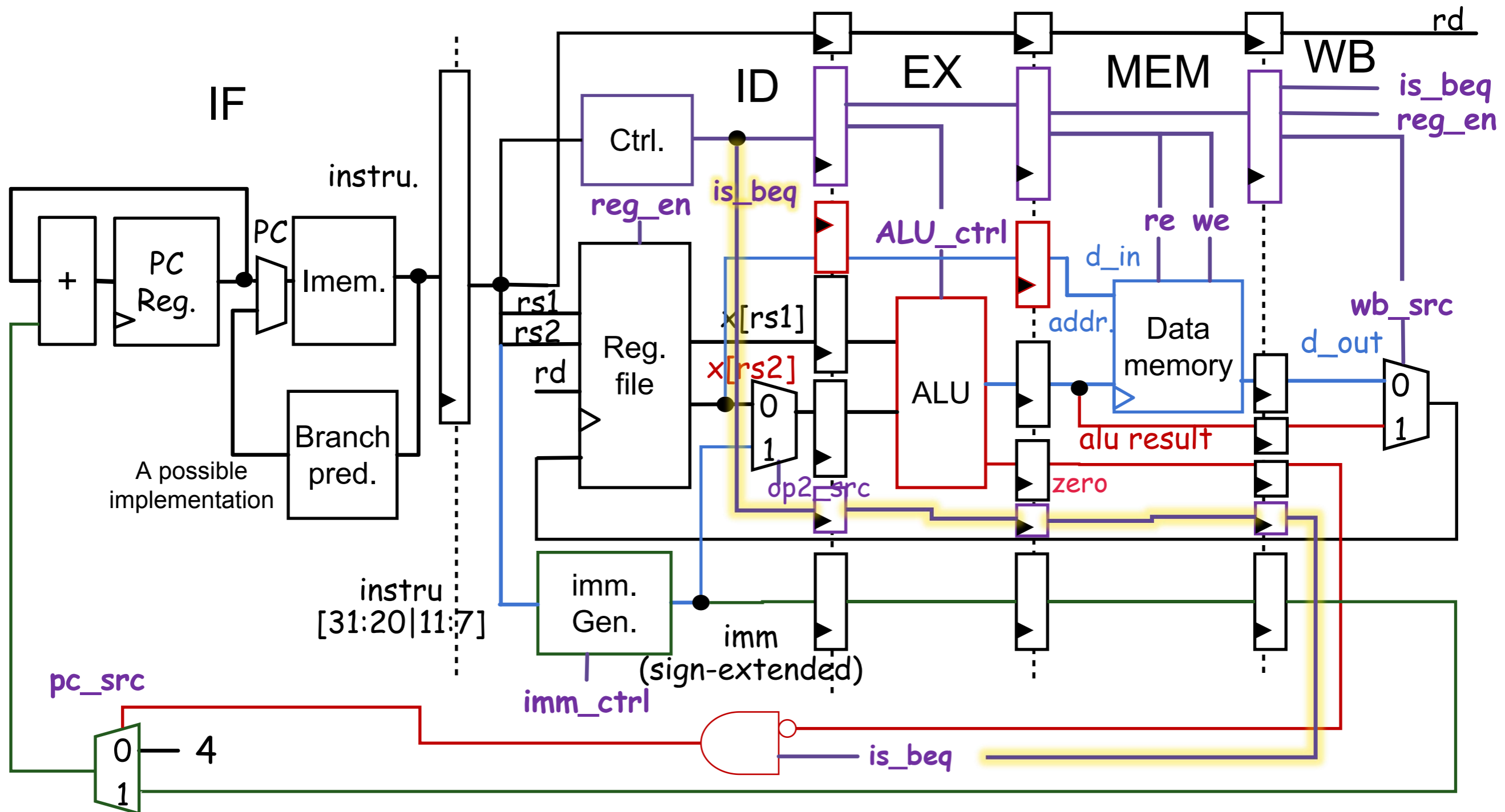

# Control hazards -- solution 3

- Use idea similar to forwarding to reduce the delay of branches

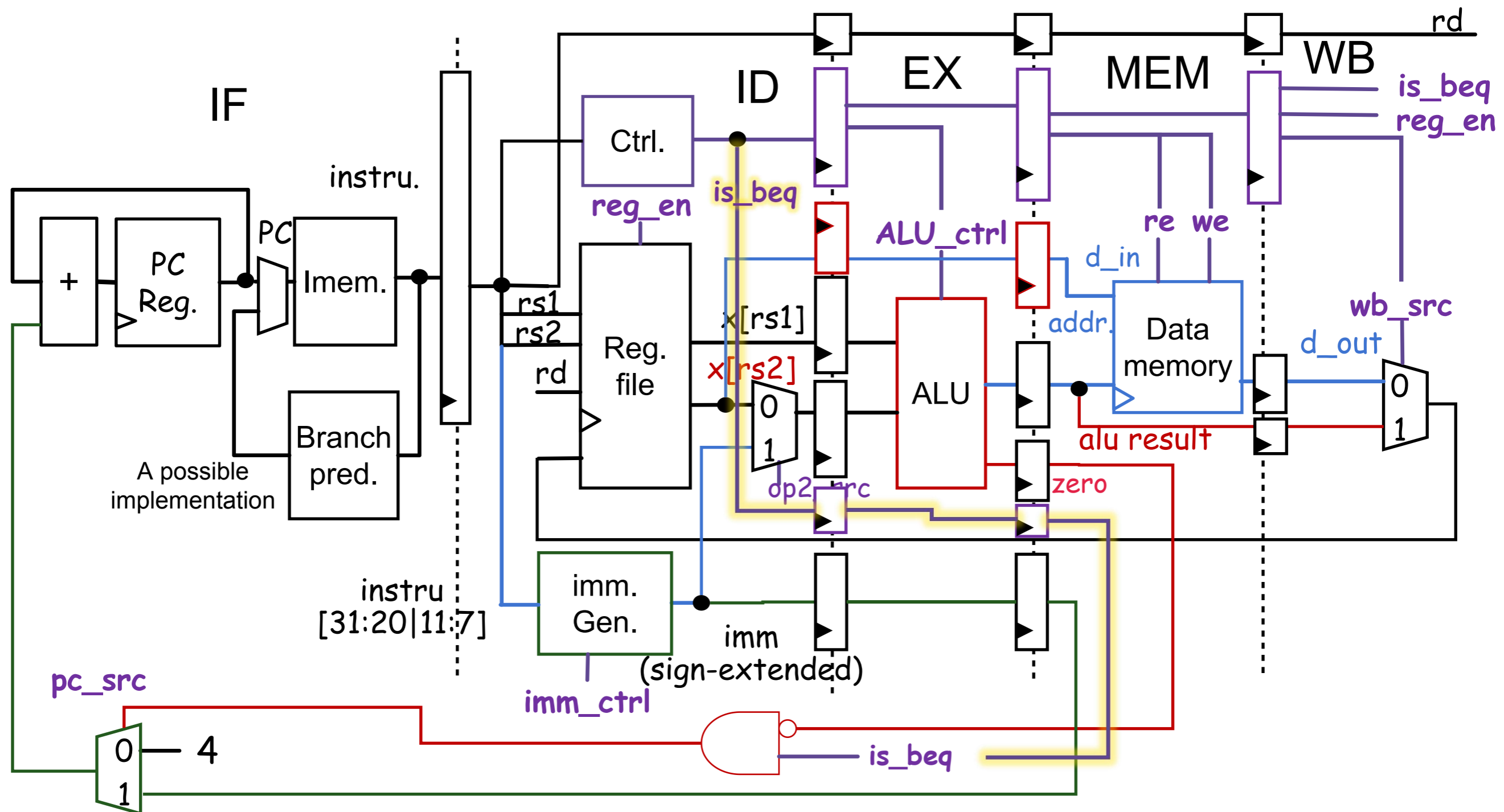

# Summary on control hazards

- The delay in determining the proper instruction to fetch is called a control hazard or branch hazard;
- Methods to deal with control hazards